



Daikin Ductless Install & Start-up (Includes R-32)

TD-7.2 Piping



Agenda

Refrigerants

Working with PVE Oil

Refrigerant Lines

Tools

Flaring

Brazing

Pressure Test and Evacuation

Triple Evacuation

System Refrigerant Charging

Wrap Up

Agenda

Refrigerants

Working with PVE Oil

Refrigerant Lines

Tools

Flaring

Brazing

Pressure Test and Evacuation

Triple Evacuation

System Refrigerant Charging

Wrap Up

- Compatible with all HFC Refrigerants
- Excellent anti-wear properties
- Better solubility with process fluids
- Superior Resistance to Cap tube blockage
- Better lubricity
- Very Hygroscopic but with no hydrolysis
- Moisture easily removed



Agenda

Refrigerants

Working with PVE Oil

Refrigerant Lines

Tools

Flaring

Brazing

Pressure Test and Evacuation

Triple Evacuation

System Refrigerant Charging

Wrap Up

- Only install driers, oil traps, or any other line components in your piping work if instructed to do so in the IOM documents – if no instruction, it's because it is NOT necessary (for Daikin).
- The only acceptable piping is ACR (copper) type tubing which is dehydrated and sealed at both ends.
 - Recommend not using if ends are not sealed or capped.



- Isolation valves can be installed in Daikin systems. Isolation valves requirements are:
 - Compatibility with R-410A and PVE (Polyvinylether) oil
 - Temperature operation range of -40°F to 300°F
 - Working pressure of 550 PSIG, capable of handling up to 700 PSIG
 - Full flow valve with 0 pressure drop
 - Bi-directional flow
 - Brazed connections
 - Service port in valve body

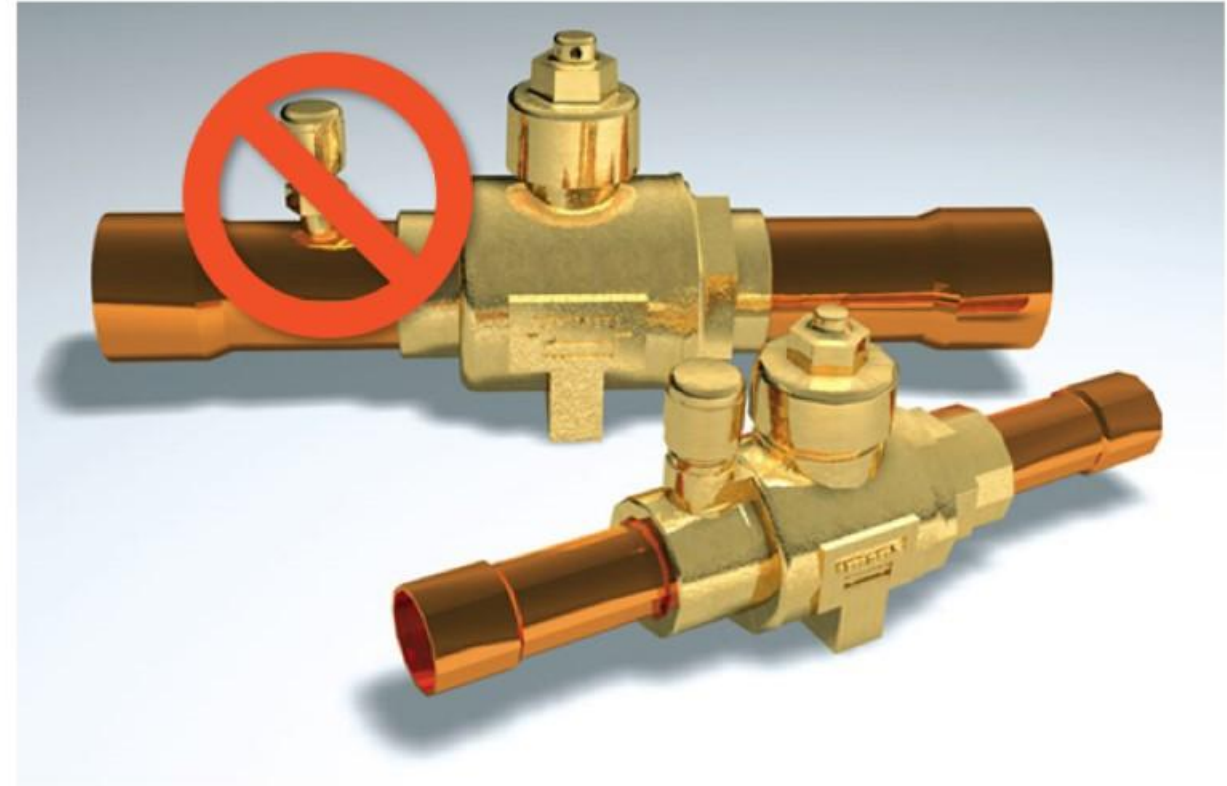

Insulating & Supporting Pipe

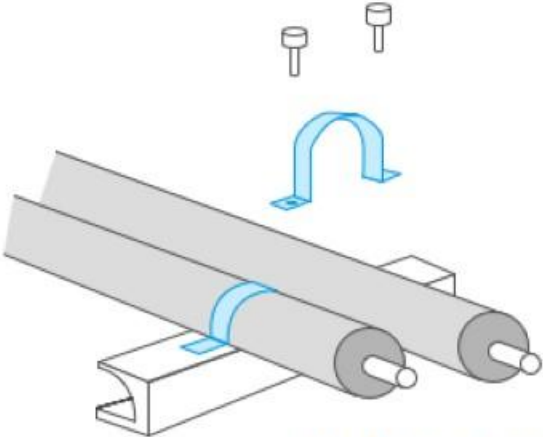
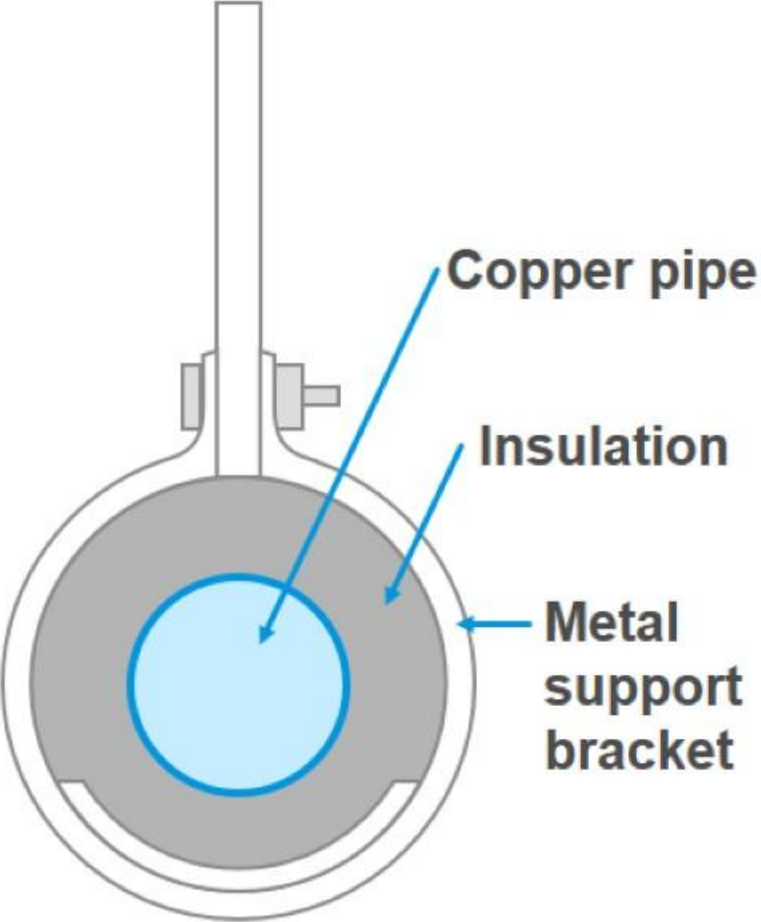

Tighten brackets so that they hold pipes in place but still allow for expansion

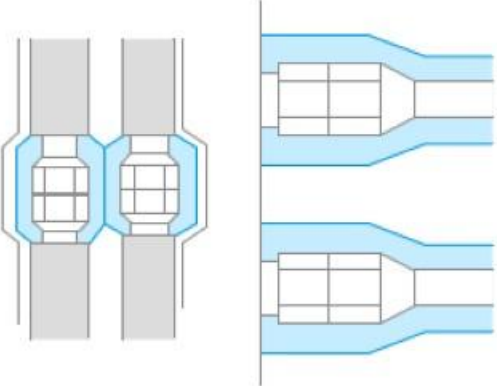

Insulate around flare nuts

- Refrigerant piping must be maintained clean.
- During installation, keep both ends of the refrigerant pipe sealed to keep out any debris
- When the piping is not connected to the indoor and outdoor units, the ends must be properly sealed.
 - There are two recommended methods of sealing the ends:
 - < 30 days - cap or tape the ends
 - > 30 days - pinch and braze the ends

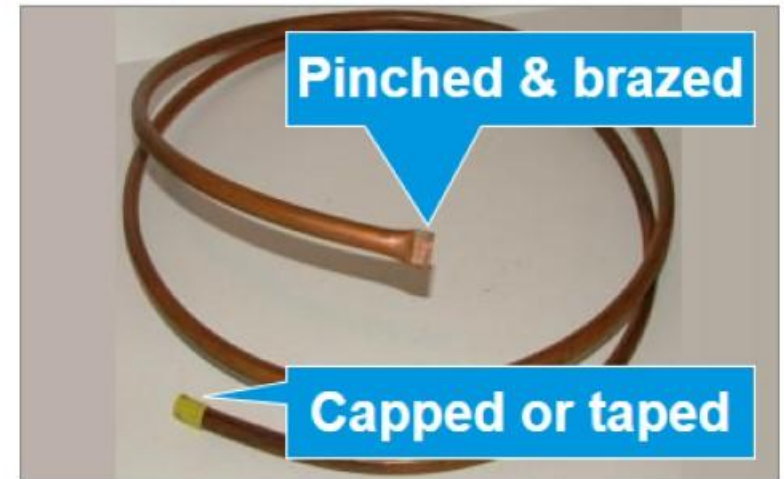

Agenda

Refrigerants

Working with PVE Oil

Refrigerant Lines

Tools

Flaring

Brazing

Pressure Test and Evacuation

Triple Evacuation

System Refrigerant Charging

Wrap Up

Tools for R32 (different from R410A?)

- Do technicians need “spark-proof tools” to work on systems containing A2L refrigerants?
 - No, the installation of A2L equipment uses the same types of tools as the installation of A1 refrigerants. Spark-proof tools are not required because the minimum ignition energy (MIE) for A2L refrigerants is considerably higher than the energy of a static spark. An open flame or high energy source is required to ignite an A2L.
- Gauge manifold
- Electronic leak tester
- Recovery unit

Tooling	R410A	R32
Gauge Manifold	Normal	Different Scale
Vacuum pump	Normal	Equipped with oil backflow prevention function
Leak detector	Normal	HFC capable Torch type models cannot be used
Recovery unit	Normal	Different – must be R32 certified
Ventilation	Recommended	Necessary (fan)
Recovery cylinder	580 psig, right thread	698 psig, left thread
Flare Nut Torque values		No change in tightening torque value.



Premium Tool Kit: Model # DACA-99S TK-2



Standard Tool Kit: Model # DACA-TLB410AD

Model #: DACA-99S TK-2

- Heat Pump Gauge & BV Ended Hose Set
- Flaring Tool
- Flare Gauge
- De-burring Tool
- Tubing Cutter
- Torque Wrench (SAE & Metric)
- Hex Set (SAE & Metric)
- Core Remover Tool
- Adapter Fittings
- Service Port Caps

Daikin Tool Kit

Manifold Gauge



Part #: ET0090

Conical Flaring Tool



Part #:
ET0050

Flare Gauge



Part #: ET0080

Torque Wrench



Part #: ET0110

De-burring Tool



Part #: ET0071

Tubing Cutter



Part #: ET0060

Daikin Tool Kit

Core Removal Tool



Part #:
ET0130

Hex Set (SAE)



5/64" thru 1/4"
Part #: ET0120

Hex Set (Metric)



1.5mm thru 8mm
Part #: ET0120

Adapter Fittings



1/4" to 5/16"
Angle/Swivel
Part #: ET0030

Adapter Fittings



1/4" to 5/16"
Adapter
Part #: ET0020

Service Port Caps



5/16" Caps
Part #: ET0040

Additional Field Tools

Nitrogen Regulator



- Nitrogen regulator capable of measuring up to 700 plus PSI is necessary for pressurizing systems to 550 PSIG

Evacuation Pump



- Having a properly maintained vacuum pump is important for evacuating a refrigerant system.
- Pump capacity minimum of 6 to 8 cfm Two Stage.
- Check Valve in Vacuum Pump.

Micron Gauge



- Vacuum Gauge w/Digital Display
- Using a micron gauge for the entire evacuation process is mandatory on all Daikin systems

Digital Scale



- A good digital scale must be used to properly weigh in the liquid R-410A refrigerant

Agenda

Refrigerants

Working with PVE Oil

Refrigerant Lines

Tools

Flaring

Brazing

Pressure Test and Evacuation

Triple Evacuation

System Refrigerant Charging

Wrap Up

Refrigerant Pipe Deburring

- When cutting copper tubing the cut ends must be properly de-burred to provide a square end to eliminate any increased chance of a leak.
- To properly remove the cut burrs, use a deburring tool to provide a smooth and square cut end in the tubing.
- Be careful to not under cut the inside tube diameter creating a chamfered edge.



Tubing with burrs

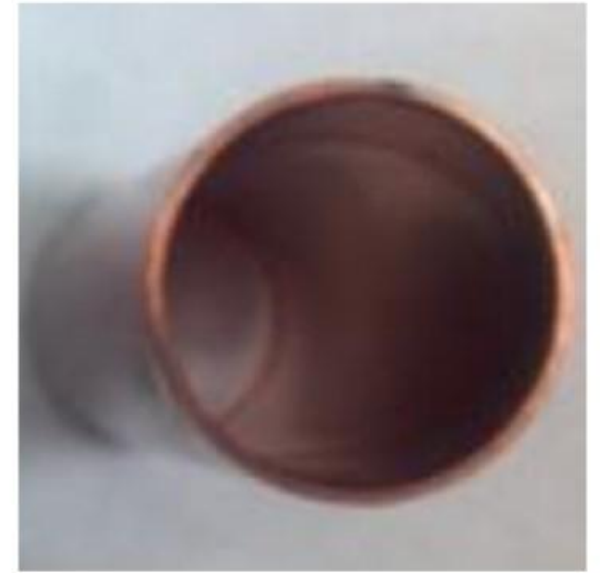

Deburred tubing



Deburring Tool

Piping Flaring

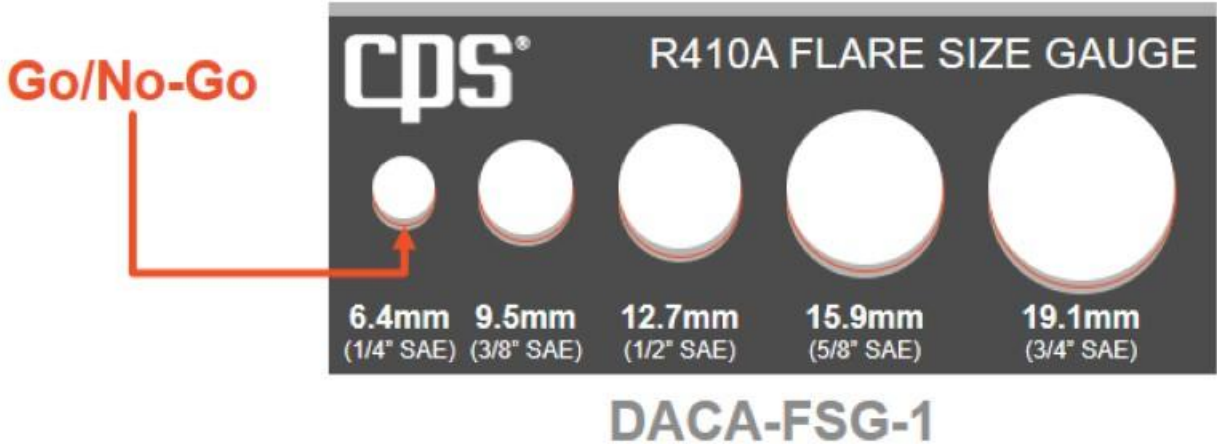
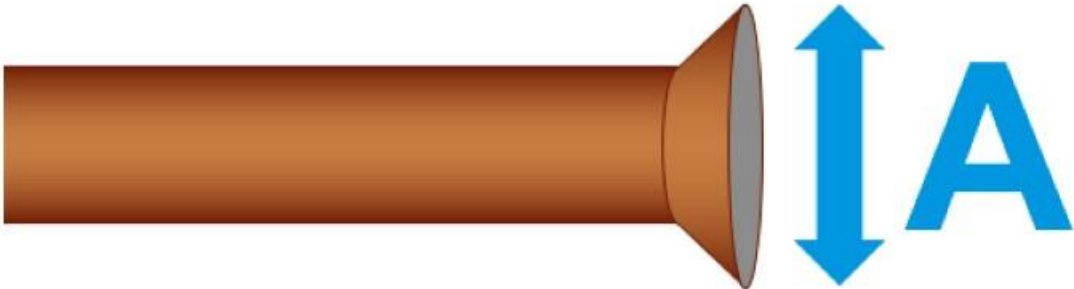

Dimension 'A' requirement	
Pipe Size	Dimension
1/4"	6.4mm
3/8"	9.5mm
1/2"	12.7mm
5/8"	15.9mm
3/4"	19.1mm

Pipe Flaring



Use the Daikin Flare Gauge to properly set depth of flare.



Agenda

Refrigerants

Working with PVE Oil

Refrigerant Lines

Tools

Flaring

Brazing

Pressure Test and Evacuation

Triple Evacuation

System Refrigerant Charging

Wrap Up



- Dry Nitrogen **MUST** be used during all brazing (Pressure regulated to 1.5 to 3 PSIG) to prevent oxidation formation.
- Tape in Schrader Fitting
- Set nitrogen regulator between 1.5 – 3.0 PSIG
- Leave other end of pipe open so nitrogen can flow through during brazing
- **For R-32 make sure to flush system with dry nitrogen before conducting any brazing**

Oxidation



No Oxidation



Agenda

Refrigerants

Working with PVE Oil

Refrigerant Lines

Tools

Flaring

Brazing

Pressure Test and Evacuation

Triple Evacuation

System Refrigerant Charging

Wrap Up



- 3 Step System Pressure Test

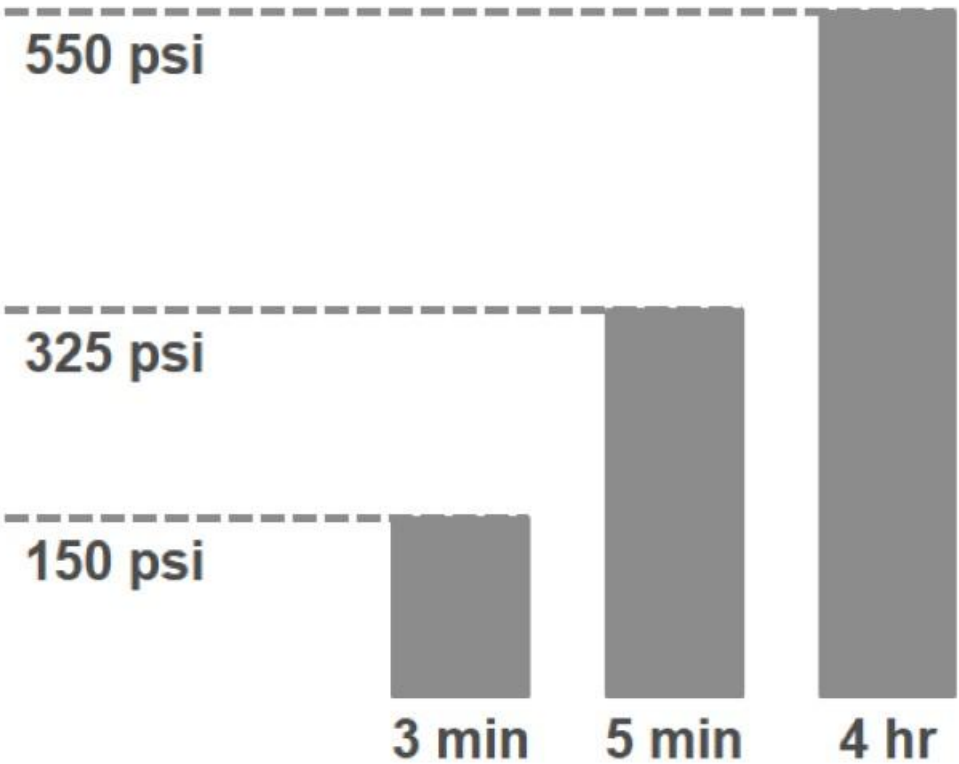

Verify all stop valves are securely closed before pressure test



- Nitrogen pressure is subject to fluctuation based on ambient temperature changes. Use this formula to compensate for temperature changes from one day to the next when performing the 4 hour pressure test. The following formula will determine system pressure drop caused by low ambient temperature.

1. Record the **T**emperature when the system is **p**ressurized **(Tp)**
2. Subtract the **T**emperature when the pressure is **c**hecked **(Tc)**
3. Multiply by a factor of 0.80 to get the **P**ressure **D**rop **(PD)**

$$(T_p - T_c) \times 0.80 = \text{Pressure Drop}$$



Use liquid leak detector



Do not use household products

DO NOT use a halide torch, chlorine-based products, or electronic leak detection with R32

Agenda

Refrigerants

Working with PVE Oil

Refrigerant Lines

Tools

Flaring

Brazing

Pressure Test and Evacuation

Triple Evacuation

System Refrigerant Charging

Wrap Up

System Triple Evacuation

- Minimum 2 CFM vacuum pump with check valve is recommended
- Older vacuum pumps MAY NOT BE certified for A2L refrigerants.
- Equipped with oil backflow prevention function (In the case of using a vacuum pump without reverse flow preventive function, use only after connecting it to a reverse flow preventive vacuum adapter.)



- Ensure vacuum rated hoses are in good condition (including O-rings)



- Digital micron gauge

Evacuation Connections

- Connect manifold gauges to suction port of outdoor unit.
- Connect vacuum pump and micron gauge
 - Recommend using the core removal tool.
- Triple evacuation down to 500 microns or less using dry nitrogen to break vacuum
 - The final vacuum is used to draw in the calculated “Additional Refrigerant Charge” amount by weight

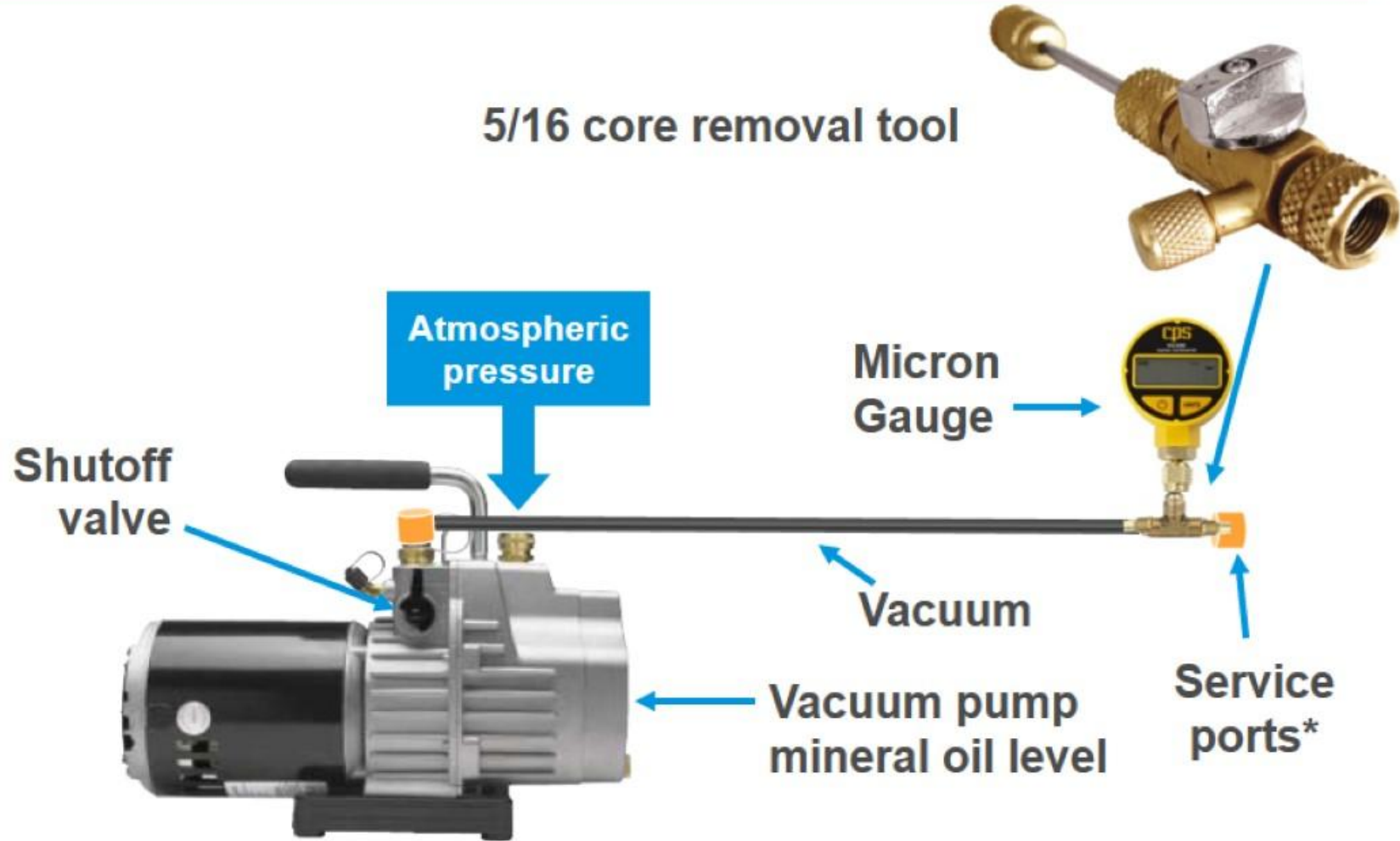

***For systems with multiple ports use removal tools with two hoses**



- Daikin Recommends Triple Evacuation
 - Evacuate the system to 4000 microns and hold for 15 minutes
 - Break vacuum with dry nitrogen to a pressure of 2-3 PSIG and hold for 20 minutes
 - Evacuate to 1500 microns and hold for 20 minutes
 - Break vacuum with dry nitrogen to a pressure of 2-3 PSIG and hold for 20 minutes
 - Evacuate below 500 microns and hold for 60 minutes

Note: when evacuation is complete use the vacuum to pull in the additional refrigerant charge.

Agenda

Refrigerants

Working with PVE Oil

Refrigerant Lines

Tools

Flaring

Brazing

Pressure Test and Evacuation

Triple Evacuation

System Refrigerant Charging

Wrap Up



**Weigh in
additional
refrigerant
with digital
scales**

- Calculate charge based on total line length x lb/ft of diameter.
- Check with each model for correct multiplier.



Installation practices

- Minimize emissions during
 - Evacuation
 - Connecting/disconnecting hoses
 - Commissioning
- Air drawn in during evacuation
- What can happen if incorrect refrigerant is used?
- Full accidental release
 - Very rare
 - Immediately ventilate with fresh air
 - Room occupants should evacuate the space immediately following any accidental release of flammable refrigerant
 - Avoid all flames/hot surfaces



